

# Power Quality and Energy Measurement PEM575

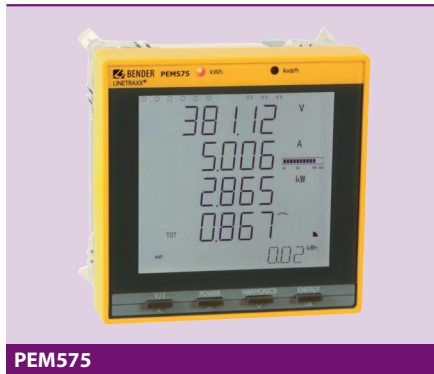

# Power Quality and Energy Measurement

## PEM575



PEM575

### Device features

- Accuracy class according to IEC 62053-22: 0.2 S
- Measured quantities
  - Phase voltages  $U_{L1}$ ,  $U_{L2}$ ,  $U_{L3}$  in V
  - Line conductor voltages  $U_{L1L2}$ ,  $U_{L2L3}$ ,  $U_{L3L1}$  in V
  - Phase currents  $I_1$ ,  $I_2$ ,  $I_3$  in A
  - Neutral current (calculated)  $I_0$  in A
  - Neutral current (measured)  $I_4$  in A
  - Frequency  $f$  in Hz
  - Phase angle for  $U$  and  $I$  in  $^\circ$
  - Power per phase conductor  $S$  in kVA,  $P$  in kW,  $Q$  in kvar
  - Total power  $S$  in kVA,  $P$  in kW,  $Q$  in kvar
  - Displacement factor  $\cos(\varphi)$
  - Power factor  $\lambda$
  - Active and reactive energy import in kWh, kvarh
  - Active and reactive energy export in kWh, kvarh
  - Voltage unbalance in %
  - Current unbalance in %
  - Harmonic distortion (THD) for  $U$  and  $I$
  - k-Factor for  $I$
- Programmable setpoint monitoring
- LED pulse outputs for active and reactive energy
- Modbus/RTU and Modbus/TCP
- 3 digital outputs
- Requirements of energy and current for particular time frames
- Peak demands with timestamps
- Individual, current/voltage harmonics up to the 63<sup>rd</sup> harmonic
- Minimum and maximum values
- Waveform recording (12.8 kHz)
- Data recorder
- Sag/swell detection
- High-resolution waveform recording
- Detection of transient events

### Product description

The digital universal measuring device PEM575 is suited for measuring and displaying electrical quantities of a public electricity network. The PEM575 is able to perform current, voltage, energy consumption and performance measurements as well as displaying individual current/voltage harmonics for assessment of the power quality. The accuracy of active energy measurements corresponds to class 0.2 S in accordance with the requirements of DIN EN 62053-22 (VDE 0418 Part 3-22). The current inputs are connected via external .../1 A or .../5 A measuring current transformers.

### Typical application

- As a compact device for front panel mounting, the PEM575 is a replacement for analogue indicating instruments
- Typical application in low and medium-voltage networks (via measuring voltage transformer)
- Power quality monitoring
- Collection of relevant data for energy management
- Cost allocation of energy consumption
- High-resolution waveform recording allow analysis of power quality phenomena

### Description of function

- Sampling rate of the measuring channels: 12.8 kHz
- Calculation of the total harmonic distortion THD<sub>U</sub>/THD<sub>I</sub>: harmonics up to the 63rd harmonic
- Individual current/voltage harmonics
- Password protection
- Clamp mechanism, no tools required
- History memory for minimum and maximum values of current, voltage, energy, power rating etc. for each month
- Inputs and outputs:
  - 3 digital outputs, 6 digital inputs
  - 16 user-programmable setpoints (response values, response delay 0...9999 seconds)
  - System protocol: 512 events, setup changes, setpoint alarming, DI status changes, DO switching operations
- Communication:
  - Galvanically isolated RS-485 interface (1,200 bis 19,200 bit/s)
  - Modbus-RTU protocol
  - Modbus TCP (10/100 Mbit/s)

### Standards

The universal measuring device for Power Quality and Energy Measurement /PEM575 was developed in accordance with the following standards: DIN EN 62053-22 (VDE 0418 Part 3-22), DIN EN 61557-12 (VDE 0413-12)

### Features

	PEM575
RS-485	■
Modbus TCP	■
Digital inputs	6
Digital outputs	3
Sampling rate	12.8 kHz
THD calculation and harmonics	63.
On-board memory	4 MB
Detection of transients	■

Operating elements

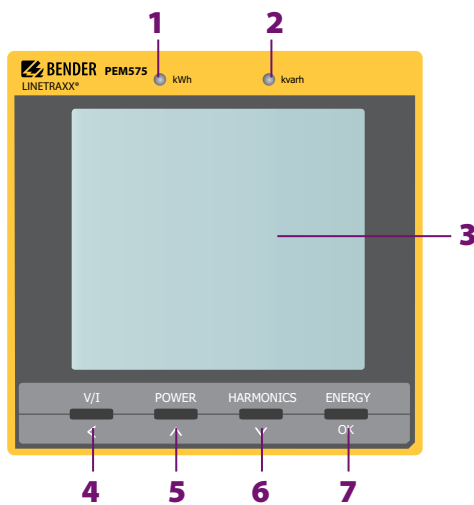

- 1 - Pulse LED: kWh
- 2 - Pulse LED: kvarh
- 3 - Display
- 4 - "V/I" button: Selection (in the menu)
- 5 - "POWER" button: Up (in the menu)
- 6 - "HARMONICS" button: Down (in the menu)
- 7 - "ENERGY" button: OK (in the menu)

Press the "ENERGY" button > 1.5 s to enter/leave the Setup menu.

Example for system set-up

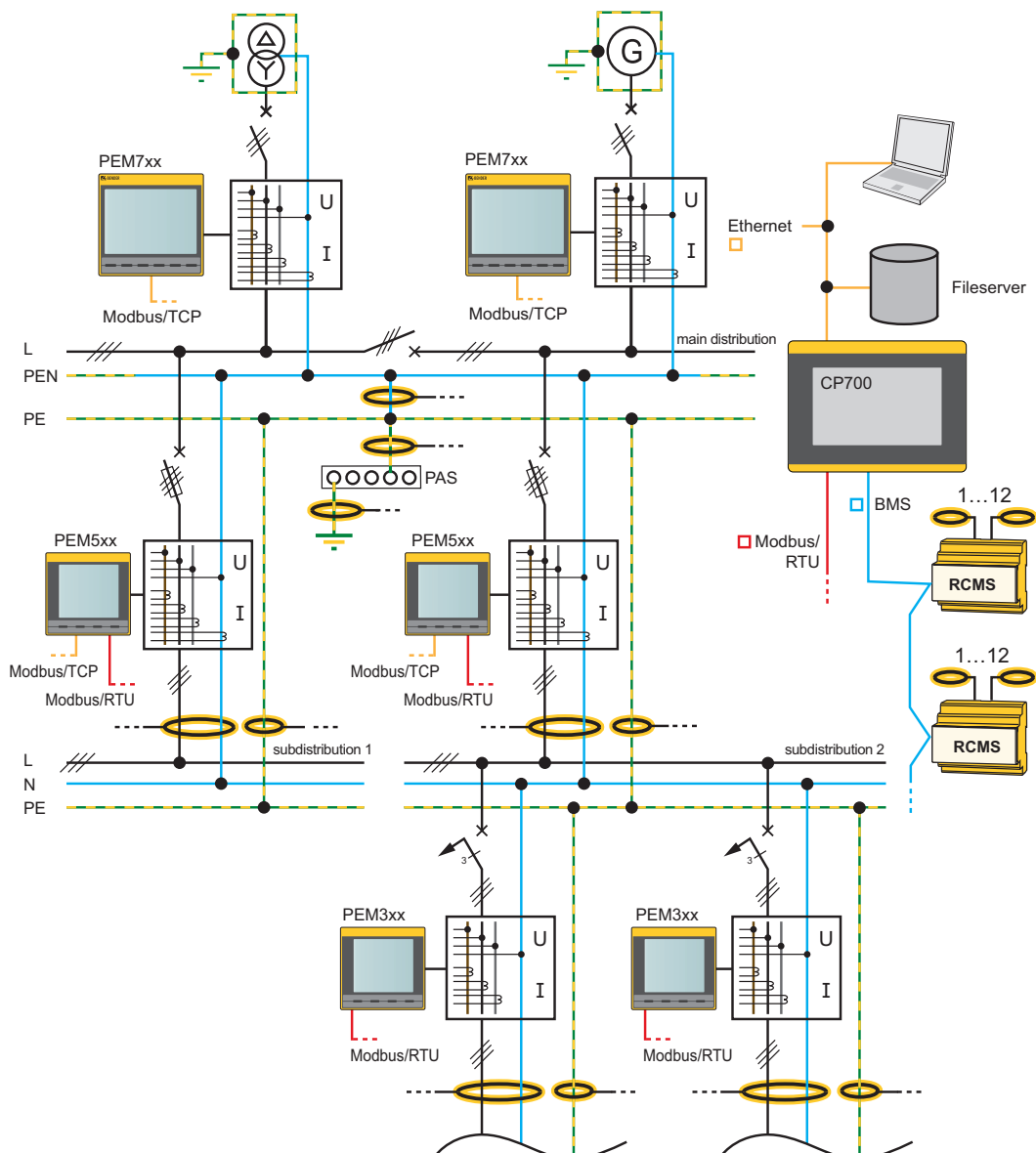

NSHV = Low-voltage main distribution board

**Wiring diagram**

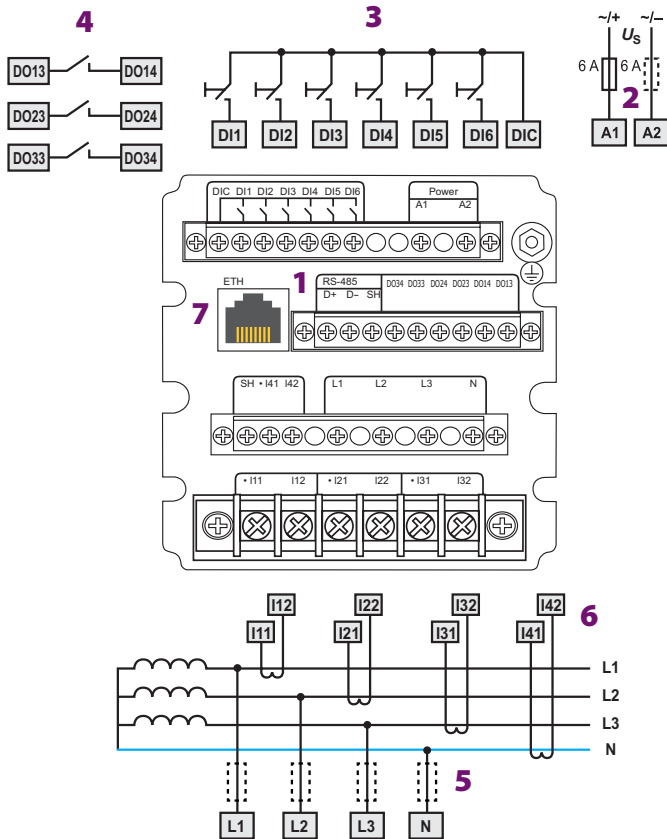

- 1 - Connection RS-485 bus
- 2 - Supply voltage. Power protection by a 6 A fuse, quick response. If being supplied from an IT system, both lines have to be protected by a fuse.
- 3 - Digital inputs
- 4 - Digital outputs (N/O contacts)
- 5 - Measuring voltage inputs
- 6 - Connection to the system to be monitored: The measuring leads should be protected by appropriate fuses.
- 7 - Connection Modbus/TCP

**Connection diagram voltage inputs**

**Three-phase 4-wire system (TN, TT, IT systems)**

The PEM can be used in three-phase 4-wire systems, independent of the type of distribution system (TN, TT, IT system).

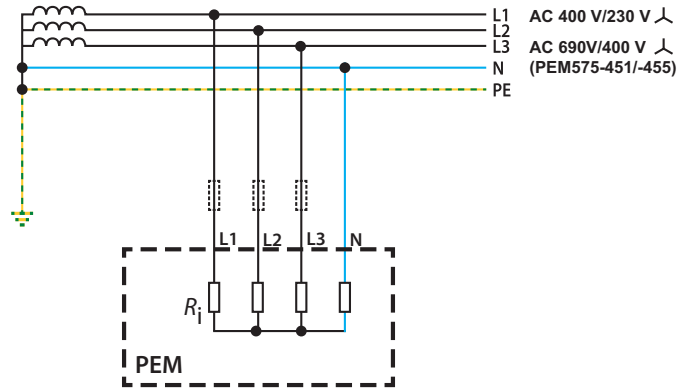

**Three-phase 3-wire system**

The PEM can be used in three-phase 3-wire systems.

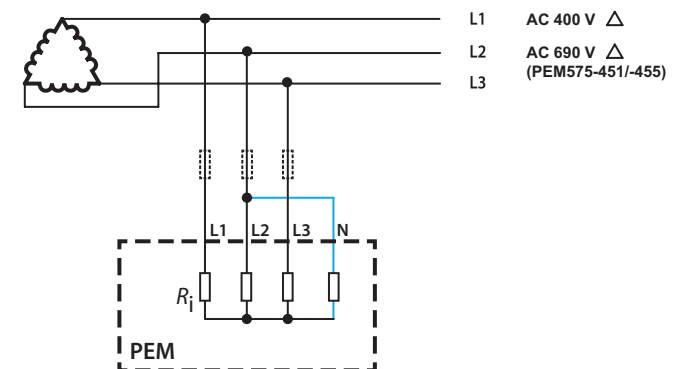

**Connection via voltage transformers**

The coupling via measuring voltage transformers allows the use of a measuring device in medium and high voltage systems. The transformation ratio in PEM575 can be adjusted (1...10000).

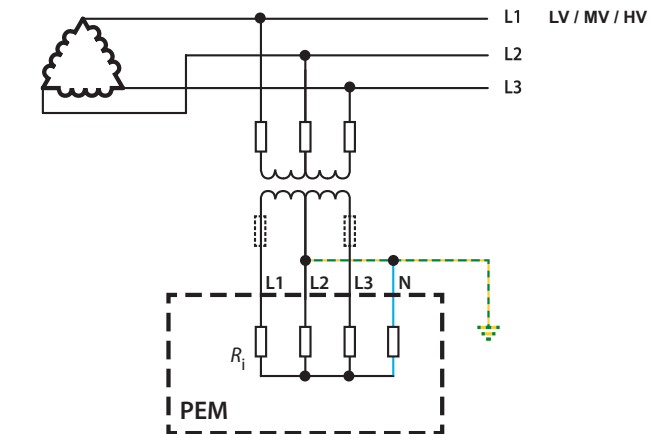

**Technical data**
**Insulation co-ordination**
**Measuring circuit**

Rated insulation voltage	300 V
Overvoltage category	III
Pollution degree	2

**Supply circuit**

Rated insulation voltage	300 V
Overvoltage category	II
Pollution degree	2

**Supply voltage**

Rated supply voltage $U_S$	95...250 V
Frequency range of $U_S$	DC, 44...440 Hz
Power consumption	≤ 11 VA

**Measuring circuit**
**Measuring voltage inputs**

$U_{L1-N, L2-N, L3-N}$	230 V 400 V (only -451, -455)
$U_{L1-L2, L2-L3, L3-L1}$	400 V 690 V (only -451, -455)
Measuring range	10... 120 % $U_N$
Rated frequency	45...65 Hz
Internal resistance (L-N)	> 500 k $\Omega$

**Measuring current inputs**

External measuring current transformer should at least comply with accuracy class 0.5 S

Burden	n.A., internal current transformers
Measuring range	0.1... 120 % $I_N$
PEM575/PEM575-455	
$I_N$	5 A
Measuring current transformer ratio	1...6000
PEM575-251/PEM575-451	
$I_N$	1 A
Measuring current transformer ratio	1...30000

**Accuracies (of measured value/of full scale value)**

Phase voltage $U_{L1-N}, U_{L2-N}, U_{L3-N}$	± 0.2 % of measured value.
Current	± 0.2 % of measured value + 0.05 % of full scale value.
Neutral current $I_4$	0.5 % of full scale value
Frequency	± 0.01 Hz
Phase position	± 1 °
Active energy measurement according to	DIN EN 62053-22 (VDE 0418 Part 3-22)
r.m.s. voltage measurement according to	DIN EN 61557-12 (VDE 0413-12), chapter 4.7.6
r.m.s. phase current measurement according to	DIN 61557-12 (VDE 0413-12), chapter 4.7.5
Frequency measurement according to	DIN EN 61557-12 (VDE 0413-12), chapter 4.7.4

**Interface**

Interface/protocol	RS-485/Modbus/RTU
Baud rate	1.2...19.2 kbits/s
Cable length	0...1200 m
Shielded cable (shield connected to terminal SH on one side)	recommended: J-Y(St)Y min. 2x0.8

Interface/protocol	Ethernet/Modbus/TCP
Baud rate	100 Mbits/s

**Switching elements**

Outputs	3 N/O contacts
Operating principle	N/O operation
Rated operational voltage	AC 230V DC 24V AC 110V DC 12V
Rated operational current	5 A 5 A 6 A 5 A
Minimum contact rating	1 mA at AC/DC ≥ 10 V
Inputs	6 electrically separated digital inputs
$I_{min}$	2.4 mA
$U_{DI}$	DC 24 V

**Environment/EMC**

EMC	DIN EN 61326-1
Operating temperature	-25...+55 °C
Climatic class acc. to DIN EN 60721	
Stationary use	3K5
Classification of mechanical conditions acc. to DIN EN 60721	
Stationary use	3M4

**Connection**

Connection	screw-type terminals
------------	----------------------

**Other**

Degree of protection, installation	IP20
Degree of protection, front	IP52
Documentation number	D00016
Weight	≤ 1100 g

## Ordering information

Interface	Nominal system voltage	Current input	Type	Art. No.
	3(N)AC			
RS-485/Ethernet	400/230 V	5 A	PEM575	B 9310 0575
		1 A	PEM575-251	B 9310 0576
	690/400 V	5 A	PEM575-455	B 9310 0577
		1 A	PEM575-451	B 9310 0578

## Dimension diagram

Dimensions in mm

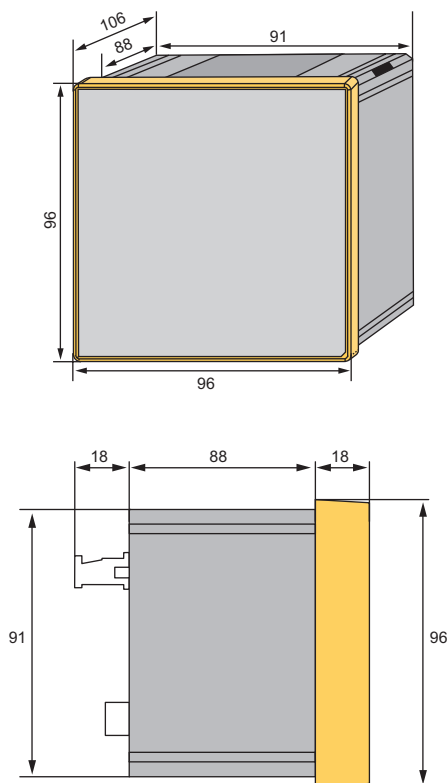

## Panel cut-out

Dimensions in mm

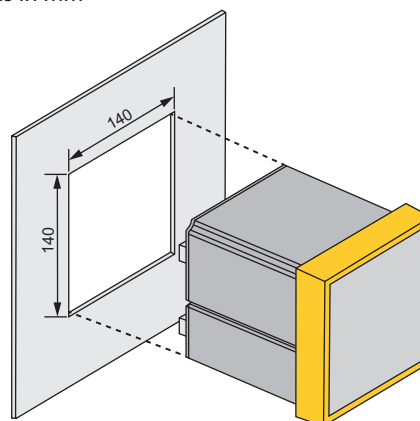

### Bender GmbH & Co. KG

P.O. Box 1161 • 35301 Gruenberg • Germany  
 Londorfer Strasse 65 • 35305 Gruenberg • Germany  
 Tel.: +49 6401 807-0 • Fax: +49 6401 807-259  
 E-Mail: info@bender.de • www.bender.de



BENDER Group